

GENERAL DESCRIPTION:

Electric oven **SNOL 360/600** is suitable for various thermal treatment processes up to 600°C, e.g. drying, preheating, normalization and other similar purposes. Oven can be applied in electronics, plastics, metal and other branches of industry. The application of induced air circulation ensures good temperature distribution throughout the chamber and fast heat treatment process.

CONSTRUCTION:

- ✓ Control panel on the left side,
- ✓ Ventilation motor on the top,
- ✓ Heating from 2 sides tubular (U-shaped) heating elements,
- ✓ Insulation with rock wool (complete lack of asbestos),
- ✓ Inside casing in 304 stainless steel,
- ✓ Outside casing in metal sheet, powder painting grey (RAL 7035), frame black,
- ✓ Door opening to the right,
- ✓ Door safety switch,
- ✓ OTP (over temperature protection),
- ✓ SSR relay.

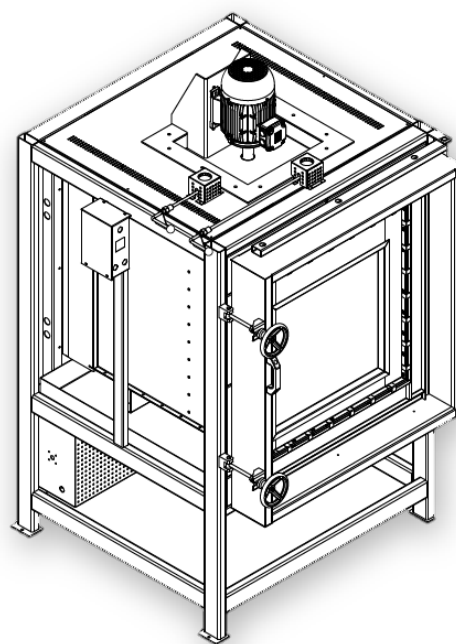

Picture – for illustration purposes only

Technical data	Dimension	SNOL 360/600 N
Chamber volume	Liter	360
Rated power not more then	kW	12*
Rated supply voltage	Volt	400
Rated frequency	Hz	50
Number of phases	-	3
Continuous operating temperature	°C	50 - 600
Maximum temperature	°C	600
Working chamber material	-	Stainless steel
Working chamber surroundings	-	Air (with hot air fan)
Airflow	-	Vertical
Shelves number (standard / maximum)		2/6
Maximum heating- up time (without charge), min	Min.	120
Temperature stability in working chamber at rated temperature in thermal steady state without charge not more than	± °C	1
Temperature uniformity in working space at rated temperature in thermal steady state without charge not more than	± °C	5
Oven working chamber dimensions:		
width	mm	600
depth	mm	700
height	mm	850
Outside dimensions:		
width	mm	1250
depth	mm	1300
height	mm	2400
Mass	kg	~600

* Might be adjusted.

CONTROL:

- ✓ Temperature measurement by thermocouple,
- ✓ PID electronic regulator – Omron E5CC (double digital display reference - temperature and measured temperature).

INSIDE VENTILATION:

- ✓ A ventilation set, long spindle motor and turbine placed on top of the unit,
- ✓ Adjustable air inlet and outlet.

SUPPLIED DOCUMENTS:

- ✓ Oven and temperature controller instructions,
- ✓ Electric diagram.

COUNTRY OF ORIGIN:

- ✓ Lithuania (EU country).
- ✓ CE marked.

PRODUCTION TIME:

- ✓ 8-10 weeks.

PAYMENT CONDITION:

- ✓ By agreement.

VALIDITY OF THE OFFER:

- ✓ 3 months.

GUARANTEE:

- ✓ 1 (one) year limited guarantee.

OPTIONS

Buzzer
 Signalling column (*lights*) + acoustic signal
 Timer (*delayed start*)
 Timer – Omron H5CX (*countdown*)
 Omron Touch screen E5CN-HT V1.1_EN
 Digital data recorder Eurotherm
 PC connection and software SNOL V2.0
 Door opens to the left,
 Place of the control box,

Pneumatic/electromechanical door lifting up,
 Additional shelves,
 Reinforced shelves,
 Reinforces bottom for heavy loadings,
 Removable bogie for convenient loading,
 Cooling system (adjustable),
 Automatic ventilation valves contro,
 Additional holes for thermocouples.

SNOL CONTROLLERS:

SNOL products are equipped with high-precision digital microprocessor Omron or Eurotherm temperature controllers fitted with self-tuning and manual PID settings. Temperature measurement is supported by thermocouple. The customer can select a basic or programmable temperature controller, which offers up to 32 programming segments (rate of temperature rise or decrease control, maintenance of pre-set temperature, automatic shutdown). A wide range of devices allows selecting the most appropriate controller for your process.



Omron E5CC



Eurotherm 3216



Eurotherm 3504



Omron E5CC-T



Eurotherm 3208



Eurotherm Nanodac

Model	Programmable	Number of programs	Number of steps in program	Connection to PC	Control method		Control signal type		Numbers of auxiliary outputs
					PID	ON/OFF	Relay	Logic (12VDC)	
Omron E5CC	○	1	2	●	●	●	●	●	3
Omron E5CC-T	●	8	32	●	●	●	●	●	3
Omron E5CN-H	○	1	2	●	●	●	●	●	2
Omron E5CN-HT	●	8	32	●	●	●	●	●	2
Eurotherm 3216	○	1	8	●	●	●	●	●	2
Eurotherm 3208	●	5	8	●	●	●	●	●	3
Eurotherm 3508	●	50	50	●	●	●	●	●	2
Eurotherm 3504	●	50	50	●	●	●	●	●	5
Eurotherm Nanodac	●	100	25	●	●	●	●	●	5
Eurotherm E+PLC100*	●	-	-	●	●	●	●	●	4

* Pid controller, recorder and PLC in one – designed for elaborate control algorithms.

COMPUTER SOFTWARE SNOL V2.0

SNOL V2.0 is computer software for data recording, viewing and configuring the temperature controller running your thermal treatment process. The software is designed for Windows operating system. Computer software allows simply run, review and display charts on thermal process temperatures and other settings.

- ✓ Supports up to 4 computer ports,
- ✓ Control of device parameters and programs via computer,
- ✓ Live, remote data viewing and configuration ,
- ✓ Graphical representation of the data,
- ✓ Data export to Microsoft Excel format,
- ✓ Ability to observe the process in a distance by internet,
- ✓ Connections RS-232 and RS-485,
- ✓ Multiple language entry (ability to install necessary language).

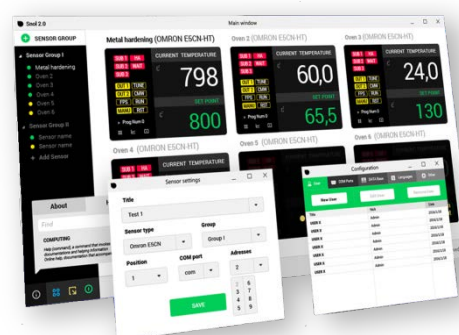

TIMER GALAXY

The main function of the timer is remote start of the furnace. The timer works in real-time. During the operation, the output contact of the timer is operated according to the settings of the dial-switches. However, at all time it is possible to manually override this operation for each channel individually.

- ✓ Start and stop 24 hour / 7 day operation,
- ✓ Stores up to 20 programs with up to 10 ON and 10 OFF events/day,
- ✓ Manual 3-way override,
- ✓ 16 Amp, 277 VAC resistive SPDT output contacts,
- ✓ Reserve carryover: 3 years (non-replaceable battery),
- ✓ 3 languages option,
- ✓ Available only with Omron devices.



DATA RECORDER

The 6100E/6100A Eurotherm 6 Channel, Ethernet Communications Paperless Graphic Recorder brings you Eurotherm excellence in a basic package to ensure you can meet your simple data recording requirements. The unit is ideal for basic visualization and recording requirements and makes an excellent replacement for small strip chart recorders - bringing you all of the cost benefits, security and flexibility of secure electronic data files.

